

# VIKING PRODUCT MANUAL

COMMUNICATION &amp; SECURITY SOLUTIONS

**1600A Series****ADA Compliant  
Emergency Phones**

May 9, 2018

## ADA\* Compliant Emergency Phones with Built-In Digital Voice Announcer

The **1600A Series** ADA Compliant Emergency Phones are designed to provide quick and reliable handsfree communication for any standard analog telephone line or analog phone system station port. All **1600A Series** phones meet ADA requirements for elevator/ emergency telephones, and can be programmed from any Touch Tone phone. The phones can dial up to 5 programmable emergency numbers, as well as 2 central station numbers. In addition, the **E-1600-20A** and **E-1600-52A** feature a second "INFO" button that will dial up to 3 non-emergency numbers.

The **1600A Series** phones can be programmed to automatically deliver a digital announcement to identify the location of the emergency call. Alternatively, a DTMF Touch Tone code may also be delivered. A "Call Connected" LED can be initiated manually or automatically. All programming parameters, including phone numbers and location numbers, are stored in non-volatile memory. All units are phone line powered, requiring no batteries or external power and are compatible with common Central Station Monitoring equipment.



For outdoor installations where the unit is exposed to precipitation or condensation, select **1600A Series** phones are available with Enhanced Weather Protection (**EWP**). EWP products feature foam rubber gaskets, sealed connections, gel-filled butt connectors, as well as urethane or thermal plastic potted circuit boards with internally sealed, field-adjustable trim pots and DIP switches for easy on-site programming. For more information, see **DOD 859**.

### Features

- **Automatic Noise Canceling (ANC) feature for clear audio in noisy environments**
- Meets the latest ASME A17.1 code when used with the optional **LV-1K** Line Verification Panel, see **DOD 246**
- Meets ADA requirements for Emergency Phones:
  - Automatically lights the "Call Connected" LED
  - Transmits a unique location I.D. code or voice announcement
  - Grade 2 Braille label for the visually impaired
- Non-volatile digital voice announcer with 16 seconds of voice memory
- Advanced call progress detection
- Handsfree operation
- Phone line powered
- Non-volatile memory (no batteries required)
- Marine grade 316 stainless steel prevents corrosion on stainless models
- Dials up to 5 emergency numbers
- **E-1600-20A** and **E-1600-52A** dial up to 3 non-emergency "INFO" #'s
- Cycles through backup phone numbers on busy or no-answer
- Optional Enhanced Weather Protection (EWP), EWP products are designed to meet IP66 Ingress Protection Rating, see **DOD 859**
- Hangs up on CPC, silence, busy signal, dial tone, time-out or touch tone command
- Programmable to auto-answer on incoming calls
- Remotely programmable
- Extended temperature range (-15°F to 130°F)
- 10 different chassis or board only available
- Available in 42" tall tower phone model **E-1600A-BLT-EWP** (**DOD 217**)
- Central Station Monitoring capability (dials 2 numbers)
- Optional **PB-100** Polling System available (**DOD 232**)
- Optional **BLK-4-EWP** strobe light kit available (**DOD 654**)
- Optional **LC-6** Six Port Concentrator available (**DOD 245**)
- Optional **LV-1K** Line Verification Panel available (**DOD 246**)
- Optional **E-1600A-MK-GNP** Pedestal Mounting Kit (**DOD 227**)
- Optional **PB-1** Panic Button Kit (**DOD 233**)
- Also available with VoIP interface, see **DOD 255** for more information

### Applications

- Elevators
- Parking ramps/lots
- Emergency pool phones
- ATM machines
- Area of refuge locations
- Lobbies
- Silent holdup alarm dialer using optional Panic Button Kit
- Entryways
- Campus emergency stations
- Roadside emergency stations
- Stadiums
- Convention centers

\* Americans with Disabilities Act of 1992 contains federal regulations regarding elevator telephones (Public Law 101-336).

**www.VikingElectronics.com**  
**Information: 715-386-8861**

### Specifications

**Power:** Telephone line powered. Minimum 24V DC talk battery voltage, with a minimum loop current of 20mA loop. Loop current may be boosted on low current lines with a Viking model **TBB-1B** Talk Battery Booster (**DOD 632**).  
**Dimensions:** See Installation and Specifications  
**Operating Temperature:** -15° F to 130° F (-26° C to 54° C)  
**Humidity - Standard Products:** 5% to 95% non-condensing  
**Humidity - EWP Products:** Up to 100%

**CAUTION - When installing on an analog extension of a phone system:** Some phone systems do not conform to analog telecom standards and might not be compatible with the **1600A Series** emergency phones. For a detailed description of the telephone line specifications required for any of the **1600A Series** phones, see **DOD 869**.

## Wiring

**⚠ IMPORTANT:** Electronic devices are susceptible to lightning and power station electrical surges from both the AC outlet and the telephone line. It is recommended that a surge protector be installed to protect against such surges.

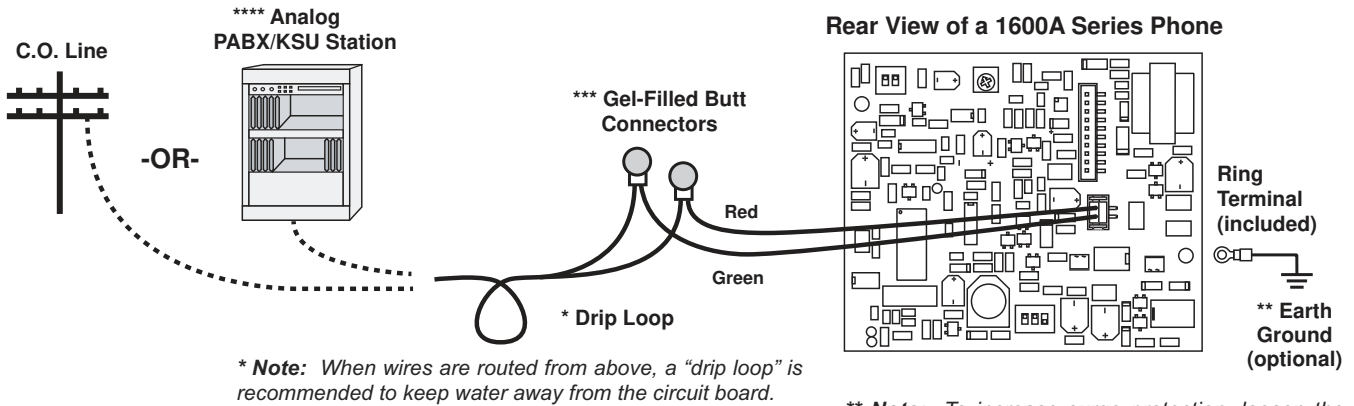

**\*\*\* Note:** The gel-filled (water-tight) butt connectors are designed for insulation displacement on 19-26 gauge wire with a maximum insulation of 0.082 inches. Cut off bare wire ends prior to terminating.

**\*\* Note:** To increase surge protection, loosen the PCB mounting screw labeled ⊕ (as shown) and fasten a wire with ring terminal (included) from the mounting screw to Earth Ground (grounding rod, water pipe, etc.)

**\*\*\*\* Note:** When installing a line powered phone on a low voltage and/or low loop current phone system extension, a **TBB-1B** Talk Battery Booster may be required. For more information on the **TBB-1B**, retrieve **DOD 632**.

## Installation and Specifications

The following sections show specifications and installation instructions for the different chassis in the 1600A Series.

**⚠ IMPORTANT:** Electronic devices are susceptible to lightning and power station electrical surges from both the AC outlet and the telephone line. It is recommended that a surge protector be installed to protect against such surges.

### E-1600A / E-1600-40A / E-1600-45A / E-1600-60A / E-1600-65A

**Dimensions:** 5.25" x 4.0" x 2.0" (133mm x 102mm x 51mm)

**Shipping Weight:** 2.5 lbs. (1.13 kg)

**Material:** .062" (16 gauge) steel

**Finish:** E-1600A - Red powder paint

E-1600-40A - Red powder paint without "EMERGENCY PHONE" verbiage

E-1600-45A - Yellow powder paint

E-1600-60A/65A - Blue powder paint

**Connections:** Gel-filled butt connectors

**Mounting:** Surface mount to walls, posts, single gang boxes or 4" x 4" electrical junction boxes or recess mount in elevator phone boxes.

**Optional Enhanced Weather Protection (EWP) Available:** The optional EWP products feature foam rubber gaskets, sealed connections, gel-filled butt connectors, as well as urethane or thermal plastic potted circuit boards. See **DOD 859**.

**Note:** For greater weather resistance, apply a bead of clear silicon caulking around the top edge and sides of the chassis.

**Optional Gooseneck Pedestal Mounting Kit:** The E-1600A-MK-GNP Mounting Kit (**DOD 227**) allows you to mount the E-1600A, E-1600-40A, E-1600-45A, E-1600-60A or E-1600-65A to a Viking VE-GNP Gooseneck Pedestal (**DOD 424**).

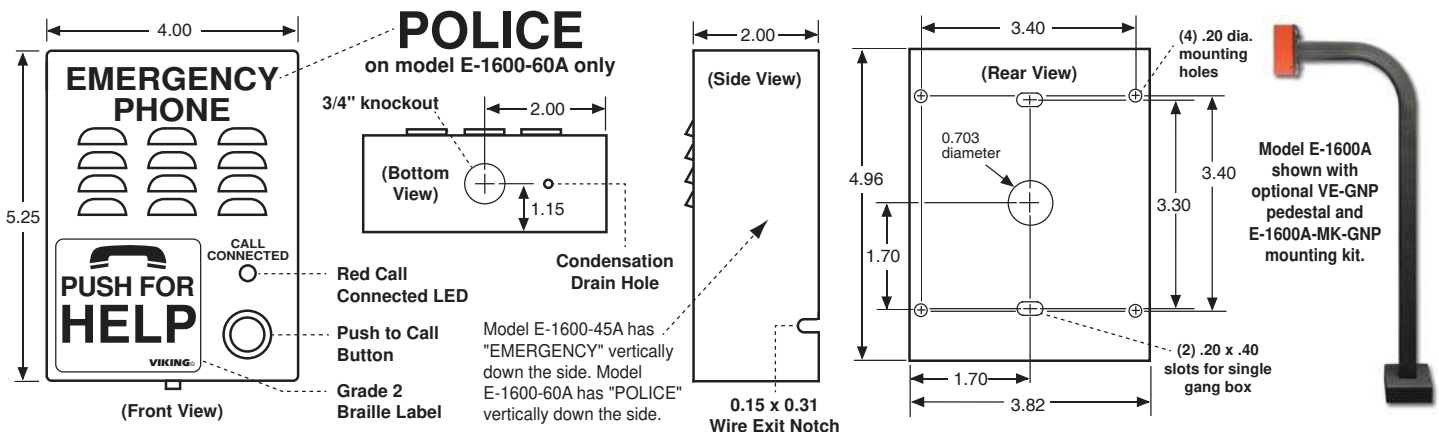

## E-1600-02A

**Dimensions:** 13" x 10.5" x 2" (330mm x 267mm x 51mm)

**Shipping Weight:** 7 lbs. (3.18 kg)

**Connections:** Gel-filled butt connectors

**Material:** .105" (12 gauge) brushed stainless steel

**Mounting:** Flush mount in elevator cabs, ATMs, stairwells, hallways, etc.

**Suggested Hardware:** (6) #8 x 3/4 flat head phillips sheet metal type A screws (not included)

**Optional Enhanced Weather Protection (EWP) Available:** The optional EWP products feature foam rubber gaskets, sealed connections, gel-filled butt connectors, as well as urethane or thermal plastic potted circuit boards. See **DOD 859**.

**Note:** When mounting outside to rough or uneven surfaces (brick, stucco, etc.) apply a bead of clear silicone caulking around the top edge and sides of faceplate.

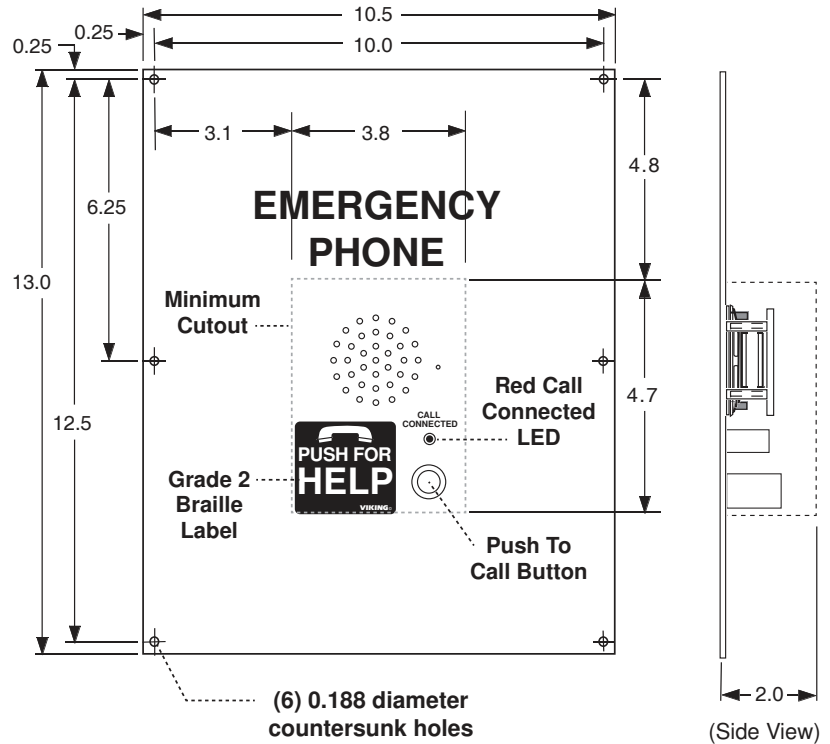

## E-1600-03B

**Dimensions:** 7.22" x 5.36" x 1.55" (183mm x 149mm x 39mm)

**Material:** 14 gauge Marine grade 316 brushed stainless steel panel

**Shipping Weight:** 3 lbs. (1.36 kg)

**Connections:** Gel-filled butt connectors

**Mounting:** Surface mount to walls, posts, single gang boxes, double gang boxes or 4" x 4" electrical junction boxes or recess mount in elevator phone boxes.

**Optional Enhanced Weather Protection (EWP) Available:** The optional EWP products feature foam rubber gaskets, sealed connections, gel-filled butt connectors, as well as urethane or thermal plastic potted circuit boards. For more information on EWP, see **DOD 859**.

**Note:** For greater weather resistance, apply a bead of clear silicon caulking around the top edge and sides of the chassis.

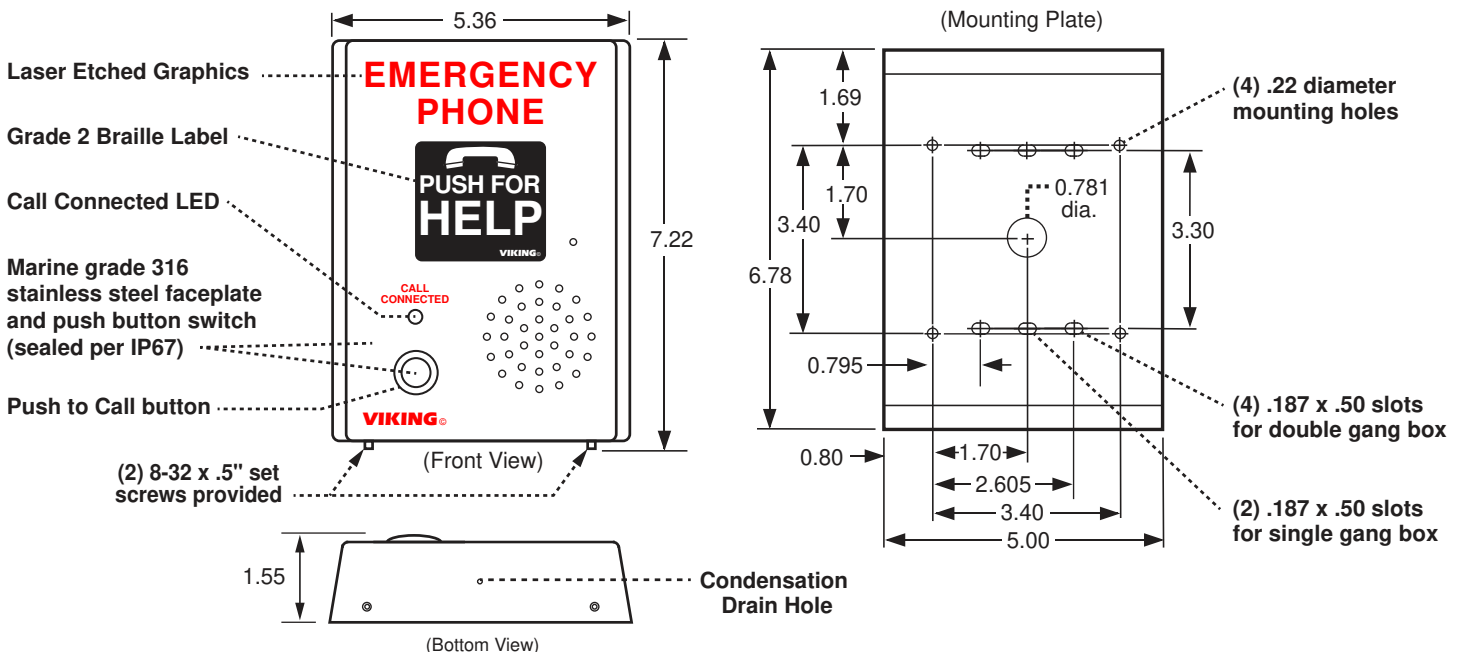

## E-1600-20A

**Dimensions:** Overall - 5.0" x 5.0" x 2.25" (127mm x 127 x 57mm), Plastic Electrical Box - 4.0" x 4.0" x 2.14" (102mm x 102mm x 54mm)

**Shipping Weight:** 2.12 lbs. (1 kg)

**Front Panel Material:** 14 gauge Marine grade 316 brushed stainless steel

**Connections:** Gel-filled butt connectors

**Optional Enhanced Weather Protection (EWP):** The optional EWP products feature foam rubber gaskets, sealed connections, gel-filled butt connectors, as well as urethane or thermal plastic potted circuit boards. See **DOD 859**.

**Mounting with Plastic Rough-In Box (included):** Flush into walls, mounts to side of wall stud **Mounting with Optional VE-5x5:** Surface mount to walls, single gang boxes, double gang boxes, posts, or to a Viking **VE-GNP** Gooseneck pedestal (see options below).

**Note:** When mounting outside to rough or uneven surfaces (brick, stucco, etc.) apply a bead of clear silicone caulking around the top edge and sides of faceplate or **VE-5x5**.

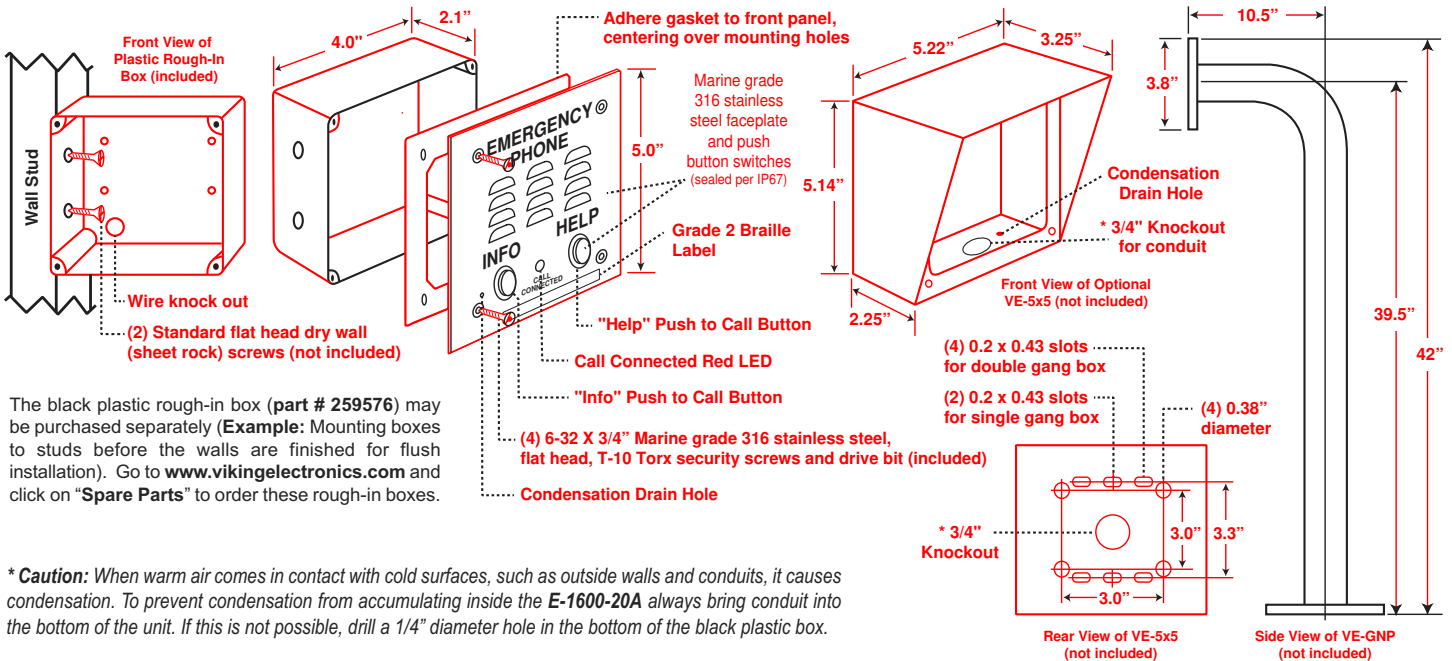

The black plastic rough-in box (part # 259576) may be purchased separately (Example: Mounting boxes to studs before the walls are finished for flush installation). Go to [www.vikingelectronics.com](http://www.vikingelectronics.com) and click on "Spare Parts" to order these rough-in boxes.

**\* Caution:** When warm air comes in contact with cold surfaces, such as outside walls and conduits, it causes condensation. To prevent condensation from accumulating inside the **E-1600-20A** always bring conduit into the bottom of the unit. If this is not possible, drill a 1/4" diameter hole in the bottom of the black plastic box.

## E-1600-30A

**Dimensions:** Overall - 127mm x 127 x 57mm (5.0" x 5.0" x 2.25"), Plastic Electrical Box - 102mm x 102mm x 54mm (4.0" x 4.0" x 2.14")

**Shipping Weight:** 1 kg (2.12 lbs.)

**Front Panel Material:** 14 gauge Marine grade 316 brushed stainless steel

**Connections:** Gel-filled butt connectors

**Optional Enhanced Weather Protection (EWP):** The optional EWP products feature foam rubber gaskets, sealed connections, gel-filled butt connectors, as well as urethane or thermal plastic potted circuit boards. See **DOD 859**.

**Mounting with Plastic Rough-In Box (included):** Flush into walls, mounts to side of wall stud **Mounting with Optional VE-5x5:** Surface mount to walls, single gang boxes, double gang boxes, posts, or to a Viking **VE-GNP** Gooseneck pedestal (as shown above).

**Note:** When mounting outside to rough or uneven surfaces (brick, stucco, etc.) apply a bead of clear silicone caulking around the top edge and sides of faceplate or **VE-5x5**.

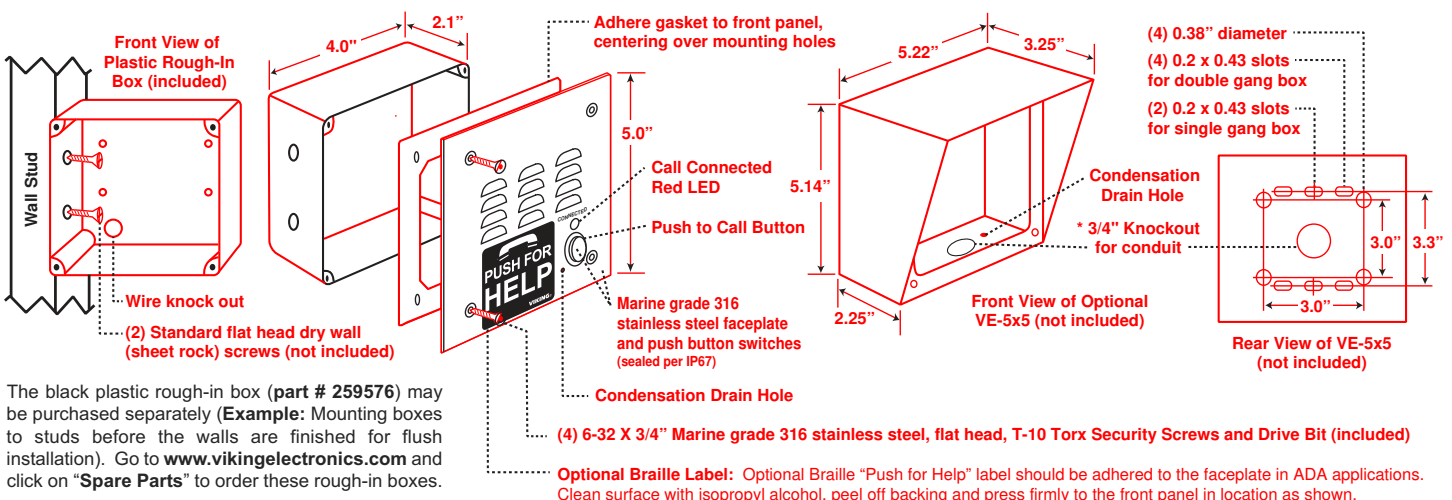

The black plastic rough-in box (part # 259576) may be purchased separately (Example: Mounting boxes to studs before the walls are finished for flush installation). Go to [www.vikingelectronics.com](http://www.vikingelectronics.com) and click on "Spare Parts" to order these rough-in boxes.

**Optional Braille Label:** Optional Braille "Push for Help" label should be adhered to the faceplate in ADA applications. Clean surface with isopropyl alcohol, peel off backing and press firmly to the front panel in location as shown.

**Important:** The **E-1600-30A** will **NOT** mount to a standard double gang box. If your application requires a double gang box, see model **E-1600-32A**.

**\* Caution:** When warm air comes in contact with cold surfaces, such as outside walls and conduits, it causes condensation. To prevent condensation from accumulating inside the **E-1600-30A** always bring conduit into the bottom of the unit. If this is not possible, drill a 1/4" diameter hole in the bottom of the black plastic box.

# E-1600-32A

The **E-1600-32A** is designed to be flush mounted to a standard double gang electrical box (minimum dimensions: 3.65"W x 2.84"H x 2.25"D).

**Dimensions:** Overall - 5.0" x 5.0" x 2.25" (127mm x 127 x 57mm)

**Shipping Weight:** 2.12 lbs. (1 kg)

**Front Panel Material:** 14 gauge Marine grade 316 brushed stainless steel

**Connections:** Gel-filled butt connectors

**Optional Enhanced Weather Protection (EWP):** The optional EWP products feature foam rubber gaskets, sealed connections, gel-filled butt connectors, as well as urethane or thermal plastic potted circuit boards. See **DOD 859**.

**Note:** When mounting outside to rough or uneven surfaces (brick, stucco, etc.) apply a bead of clear silicone caulking around the top edge and sides of faceplate. For surface mount applications, use model **E-1600-30A** with a **VE-5x5** surface mount box.

**"Old Work" Double Gang Rough-In Box\***  
Flush into walls, mounts to side of wall studs, etc.  
(Example: Allied Molded 9312 box shown below, not included)

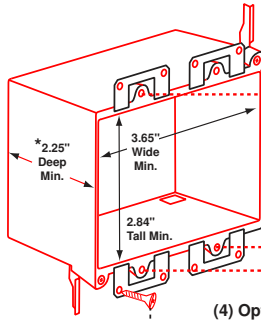

(4) Optional Dry Wall Screws (not included)

Peel paper liner and adhere gasket to back of panel, centering over mounting holes. **Caution:** For rough surfaces (ie: brick, stucco, etc.) additional caulking may be required.

(4) T-10 Torx stainless steel, flat head, security screws and drive bit (included)

Call Connected Red LED

Marine grade 316 stainless steel faceplate and push button switches (sealed per IP67)

"Help" Push to Call Button

Laser Etched Graphics

BL-1 grade 2 black Braille label included



\* **Caution:** Excessive wire length and/or using a rough-in box with inadequate depth can apply force to the circuit board causing physical damage.

**Important:** When warm air comes in contact with cold surfaces, such as outside walls and conduits, it causes condensation. To prevent condensation from accumulating inside the **E-1600-32A** always bring conduit into the bottom of the unit. If this is not possible, drill a 1/4" diameter hole in the bottom of the double gang box.

# E-1600-50A / E-1600-52A

**Note:** This is a **1600A** parts kit without chassis.

**Shipping Weight:** 1 lb (0.45 kg)

**Connections:** Gel-filled butt connectors

**Optional Enhanced Weather Protection (EWP) Available\*:** The optional EWP products feature foam rubber gaskets and boots, sealed connections, gel-filled butt connectors, as well as urethane or thermal plastic potted circuit boards. See **DOD 859**.

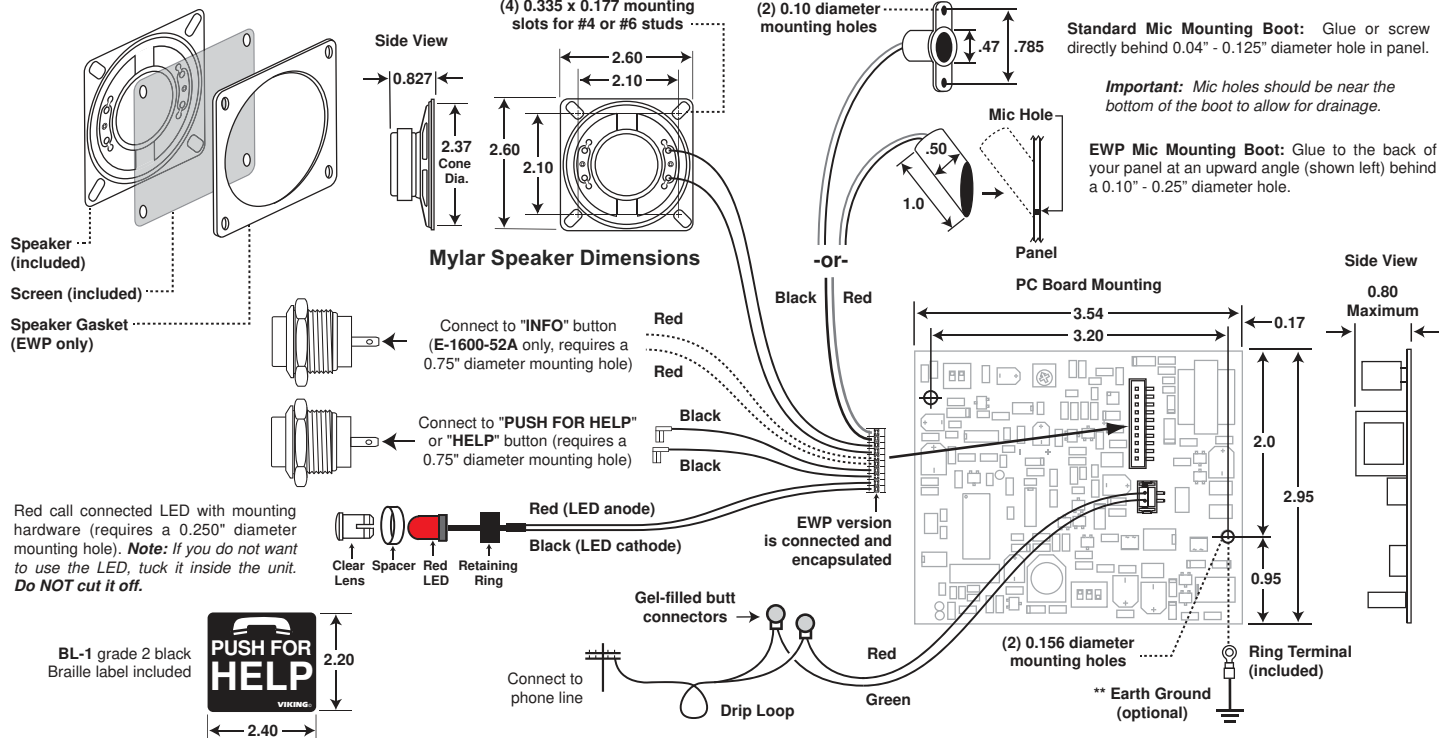

\* **Important:** If installing the **EWP** version outdoors, apply a non-corrosive silicone to back side of LED and push button switches after making all connections and testing. Completely encapsulate exposed switch connections (terminals/stripped wires) and bare wire connections.

\*\* **Note:** To increase surge protection, loosen the PCB mounting screw labeled  $\oplus$  (as shown) and fasten a wire with ring terminal (included) from the mounting screw to Earth Ground (grounding rod, water pipe, etc.)

## E-1600-55A

The **E-1600-55A** is a universal emergency phone kit for installing behind elevator panels, or an installation requiring a custom panel. The finished panel should provide: (4) studs (#6 diameter minimum) for mounting plate, audio holes for speaker and microphone, a momentary SPST push button switch and a 0.25" diameter mounting hole for the LED. Alternatively, the LED can be cut off and the wires connected to a integral switch with LED (often found in elevators). **Note:** An LED must be connected to the red and black wires for the phone to operate.

**Optional Enhanced Weather Protection (EWP) Available:** The optional EWP products feature foam rubber gaskets and boots, sealed connections, gel-filled butt connectors, as well as urethane or thermal plastic potted circuit boards. See **DOD 859**.

**Shipping Weight:** 1.6 lbs (0.73 kg)  
**Connections:** Telco and Switch - Gel-filled butt connectors  
**Material:** 0.062" thick (16 gauge) zinc plated steel

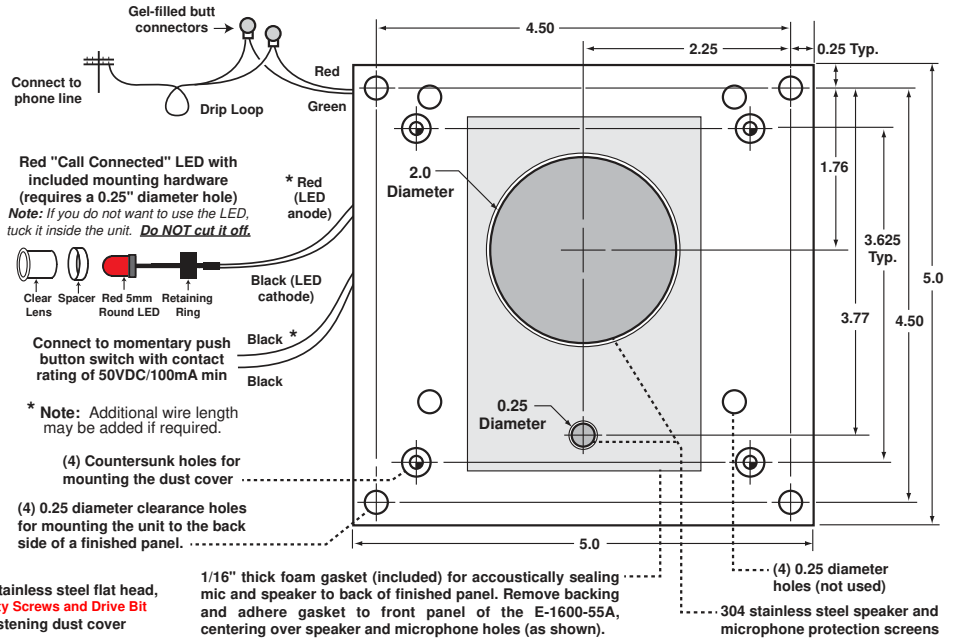
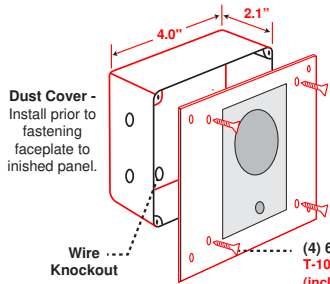

## K-1600-EHFA

**Dimensions:** 9.875" x 6.86" x 2.10" (251mm x 174mm x 53mm)  
**Shipping Weight:** 2 lbs. (0.91 kg)  
**Material:** .062" (14 gauge) red powder painted aluminum  
**Connections:** Gel-filled butt connectors  
**Mounting:** Recess mount in a standard elevator phone box (10.0" x 7.0" x 3.0")

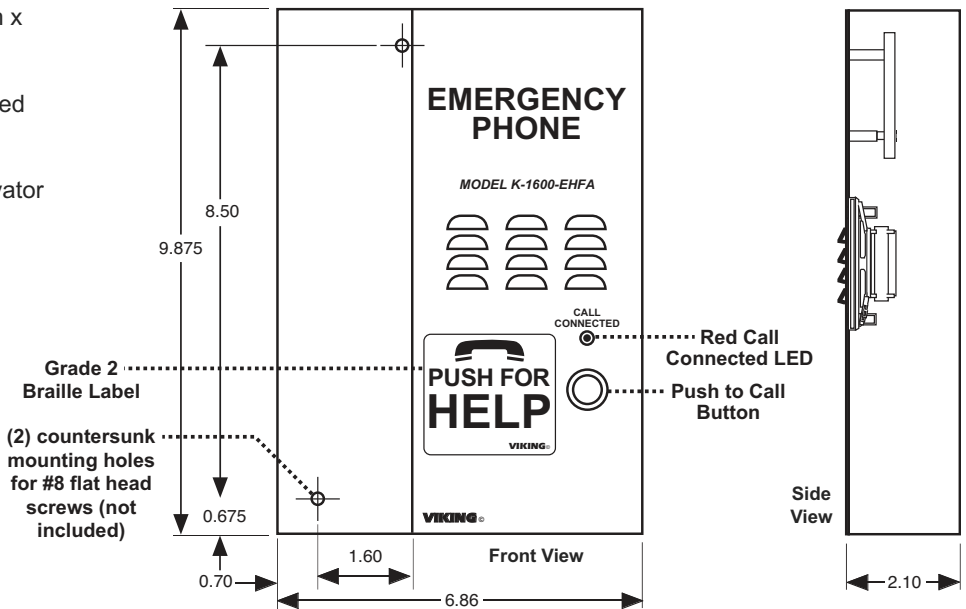

## Programming

### A. Accessing the Programming Mode

The **1600A Series** emergency phones can be programmed from any Touch Tone phone using a C.O. line, analog PABX/KSU station, or a **DLE-200B** Line Simulator. For more information on the **DLE-200B**, see **DOD 605**.

#### 1. Using the Security Code

<b>Step 1.</b>	Move DIP switch 2 to the <b>ON</b> position (sets unit to answer incoming calls, see section J).
<b>Step 2.</b>	From a Touch Tone phone call the line attached to the <b>1600A Series</b> phone.
<b>Step 3.</b>	When the <b>1600A Series</b> phone answers, enter the 6-digit security code (factory set to <b>845464</b> , see section C). A double beep should then be heard indicating you have entered the programming mode.

## 2. Without the Security Code

<b>Step 1.</b>	Move DIP switch 2 to the <b>ON</b> position (sets unit to answer incoming calls, see section J).
<b>Step 2.</b>	Move DIP switch 3 to the <b>OFF</b> position (incoming calls enter Programming without security code, see section J).
<b>Step 3.</b>	From a Touch Tone phone call the line attached to the <b>1600A Series</b> phone.
<b>Step 4.</b>	When the <b>1600A Series</b> answers, a double beep will be heard and will automatically enter the programming mode.
<b>Step 5.</b>	When finished programming, move DIP switch 3 back to the <b>ON</b> position (see section J).

**Warning:** Failure to do step 5 above will cause the **1600A Series** phone to call Viking Technical Support instead of your programmed emergency number. See Section I, Assisted Programming.

## B. Security Code (memory location #19)

The security code allows the user/installer to program the **1600A Series** phone while DIP switch 3 is in the **ON** (normal) position. The factory set security code is 845464 (V-I-K-I-N-G). It is recommended that the factory set security code be changed. **Example:** To store 123456 as the security code:

<b>Step 1.</b>	Access programming as shown in <b>Programming</b> section A.
<b>Step 2.</b>	Enter <b>123456 #19</b> .
<b>Step 3.</b>	Hang-up.

<b>Enter Your Security Code Here:</b>					
					<b>#19</b>

**Note:** The security code must be 6 digits and cannot include a \* or a #.

## C. Quick Programming Features

Description	Enter Digits	+	Memory Location
First emergency speed dial number	0-20 digits	then	<b>#00</b>
Second emergency speed dial number	0-20 digits	then	<b>#01</b>
Third emergency speed dial number	0-20 digits	then	<b>#02</b>
Fourth emergency speed dial number	0-20 digits	then	<b>#03</b>
Fifth emergency speed dial number	0-20 digits	then	<b>#04</b>
Central station receiver number	0-20 digits	then	<b>#05</b>
Central station voice number	0-20 digits	then	<b>#06</b>
First "Info" speed dial number (E-1600-20A / E-1600-52A only)	0-20 digits	then	<b>#07</b>
Second "Info" speed dial number (E-1600-20A / E-1600-52A only)	0-20 digits	then	<b>#08</b>
Third "Info" speed dial number (E-1600-20A / E-1600-52A only)	0-20 digits	then	<b>#09</b>
Voice announcer/miscellaneous options (factory set to 001210)	6 digits	then	<b>#17</b>
Timing/Dialing options (factory set to 234721)	6 digits	then	<b>#18</b>
Security code (factory set to 845464)	6 digits	then	<b>#19</b>
Identification number (factory cleared)	0-20 digits	then	<b>#20</b>
Second central station identification number (factory cleared)	0-20 digits	then	<b>#21</b>
To add a * at any point in the dialing string	**		
To add a # at any point in the dialing string	*#		
To add a four second pause at any point in the dialing string	*7		
To clear any speed dial number	(no digits)	then	<b>#00 - #09</b>
Diagnostic tones (used to check mic and speaker operation)	*0		
Exit programming and disconnect	#7		
Reset all programming to factory default settings	###		

**Note:** A double beep indicates a valid memory position, four beeps indicate an error.

## D. Speed Dial Numbers

**Note:** Up to 20 digits can be stored in each dial position. Special features such as pause, mode change, touch tone \* and # count as single digits.

### 1. Emergency Speed Dial Numbers (memory locations #00 - #04)

The emergency speed dial number programmed in location **#00** is the number that is dialed when the "HELP" button is first pressed. Additional speed dial numbers will be dialed when there is no answer or a busy signal is detected and the next number redial features are activated. To program, enter the desired speed dial number followed by the location number (**#00 - #04**). To clear a speed dial location, simply enter the memory location (**#00 - #04**) alone. The **1600A Series** phone is factory set with no speed dial number programmed.

To Program:	Enter:
*	**
#	*#
4 second pause	*7
0, 1, 2 .... 9	0, 1, 2 .... 9

**2. “INFO” Speed Dial Numbers (E-1600-20A/52A Only) (memory locations #07 - #09)**

The information speed dial number programmed in location #07 is the telephone or extension number that is dialed when the “INFO” button is first pressed. Additional information speed dial numbers will be dialed when there is no answer and the next number redial feature is activated. The E-1600-20A phone will cycle through the programmed speed dial numbers until answered. To program, enter the desired speed dial number followed by the location number (#07 - #09). To clear a speed dial location, simply enter the location (#07 - #09) alone.

**3. Speed Dial Programming Examples**

To Program the 1600-IP Series Phone...	Step 1	Step 2
...to store 555-1234 as the first emergency speed dial number	Access Programming (see page 6)	Enter digits: <b>5 5 5 1 2 3 4 # 0 0</b>
...to store a touch tone 9, a four second pause, and then 333-4444 into the second “Info” speed dial memory position	Access Programming (see page 6)	Enter digits: <b>9 *7 3 3 3 4 4 4 4 # 0 8</b>
...to clear the first emergency speed dial number	Access Programming (see page 6)	Enter digits: <b># 0 0</b>

**E. Identification Number (memory location #20)**

The Touch Tone I.D. number (up to 20 digits) is used by emergency personnel to identify the location of the caller and is given out when the receiving party presses a Touch Tone \*. The security office can display the number using a Touch Tone decoder. To program the I.D. number, enter the desired number followed by #20. **Example:** To store 333 as the I.D. number, enter: **3 3 3 # 2 0**

**F. Timing/Dialing Options (memory location #18)**

There are six positions in the timing/dialing options. To program these options, enter the six desired timing/dialing numbers followed by #18. The six available timing/dialing options are defined as follows:

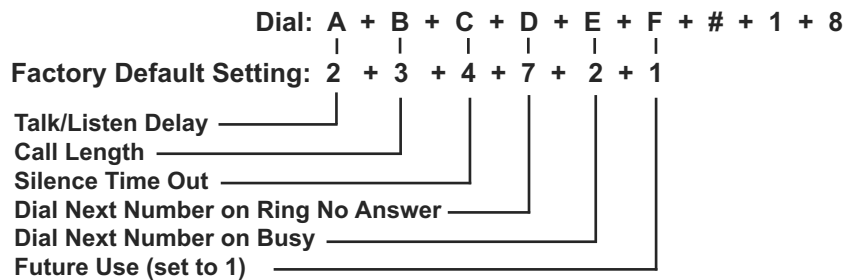

Enter Timing/Dialing Settings Here:

A	B	C	D	E	F	
						#18

Touch Tone	Talk/Listen Delay
1	0.1 seconds
2	0.2 seconds*
3	0.3 seconds
4	0.4 seconds
5	0.5 seconds
6	0.6 seconds
7	0.7 seconds
8	0.8 seconds
9	0.9 seconds

Touch Tone	Call Length Time Out
0	Disabled
1	1 minute
2	2 minutes
3	3 minutes*
4	4 minutes
5	5 minutes
6	6 minutes
7	7 minutes
8	8 minutes
9	9 minutes

Touch Tone	Silence Time Out
0	Disabled
1	10 seconds
2	20 seconds
3	30 seconds
4	40 seconds*
5	50 seconds
6	60 seconds
7	70 seconds
8	80 seconds
9	90 seconds

**Setting A - Talk/Listen Delay**

This feature selects switching time between talk and listen modes (VOX switching time). Use chart at the right. \* **Note:** The factory default is .2 seconds.

**Setting B - Call Length Time Out**

This feature selects the maximum length of time that calls can be connected. Programmable in increments of 1 minute up to a maximum of 9 minutes (Touch Tones 1 - 9). Program 0 in this location to disable the call length time out. With the call length disabled, the **1600A Series** phone must rely on a CPC signal, busy signal, silence or return to dial tone to hang-up. Use chart at the right. \* **Note:** The factory default is 3 minutes.

**Setting C - Silence Time Out**

This feature selects the length of time that calls will remain connected without voice activity. Programmable in increments of 10 seconds up to a maximum of 90 seconds (Touch Tones 1 - 9). To disable the silence time out, program 0 in this location. Use chart at the far right. \* **Note:** The factory default is 40 seconds.



### Setting D - Dial Next Number on Ring No Answer

If enabled and a ring-no-answer is detected, the **1600A Series** phone will dial the next programmed speed dial number, and continue to cycle through the emergency numbers until a call is completed. **\*Note:** *Factory set to redial if not answered after 7 rings.*

Touch Tone	Setting D
1 or 0	Disabled*
2, 3, 4...9	Dials second number after 2, 3, 4...9 rings respectively

### Setting E - Dial Next Number on Busy

If enabled and a busy is detected, the **1600A Series** phone will dial the next programmed speed dial number, and continue to cycle through the numbers until a call is completed. **\*Notes:** *This feature is enabled in the factory default setting. If the busy signal is interrupted with a promotional message, contact your central office to have it removed.*

Touch Tone	Setting E
1	Disabled
2	Enabled*

### Setting F - Future Use (set to 1)

## G. Voice Announcer/Miscellaneous Options (memory location #17)

The **1600A Series** phones have a built-in non-volatile digital voice announcer that may be used to identify the location of the emergency phone call. The 16 seconds of digital record time is recorded remotely from a Touch Tone phone. Programming options are as follows:

Dial: A + B + C + D + E + F + # + 1 + 7

Factory Default Setting: 0 + 0 + 1 + 2 + 1 + 0

Two Digit Announcement Delay { \_\_\_\_\_ }

Repeat Announcement Setting \_\_\_\_\_

Hang-up on Return to Dial Tone \_\_\_\_\_

Double Ring Cadence \_\_\_\_\_

Lap Counter \_\_\_\_\_

**Enter Settings Here:**

A	B	C	D	E	F	#17

### Settings A and B - Announcement Delay

The **1600A Series** phone is factory set to automatically start playing the voice announcement after it has determined the call has been answered. Alternately, the announcement may be programmed to play after a programmed amount of time, from 1 to 99 seconds after dialing. **\*Note:** *If the announcement delay time is used, you must allow enough time for the 1600A series phone to detect ring-no-answer and busy signals when using the redial features. The factory default is set to play automatically.*

Touch Tone	Setting A / B
00	Play automatically
01-99	1-99 seconds*

### Setting C - Repeat Announcement Option

The **1600A** can be programmed to play the announcement from 1-9 times, or to continuously repeat the announcement every 8 seconds until a Touch Tone \* is detected from the distant party. The call connected LED will turn on automatically after the announcement has stopped repeating. **\*Note:** *The factory default for the 1600A series phone is to play the voice announcement once (digit 1).*

Touch Tone	Setting C
0	Repeat every 8 seconds
1-9	Play 1-9 times*

### Setting D - Hang Up on Return to Dial Tone

If enabled and a return dial tone is detected, the **1600A** will hang up. **\*Note:** *The factory default setting is enabled.*

Touch Tone	Setting D
1	Disabled
2	Enabled*

### Setting E - Double Ring Cadence Mode

The **1600A Series** phone can be programmed to recognize the double ring cadence that is typical of many phone systems. If the **1600A Series** phone is connected to an extension that provides a double ring cadence, enabling this mode will allow for proper call progress detection. **\*Note:** *This feature is disabled in the factory default setting.*

Touch Tone	Setting E
1	Disabled*
2	Enabled

### Setting F - Lap Counter

With the lap counter disabled (factory setting), if the **1600A Series** phone is programmed to dial the next number on ring-no-answer and/or busy signal (see page 8), the **1600A Series** phone will continuously call its programmed phone numbers forever until the call is answered.

The lap counter is a programmable counter that determines how many times the **1600A Series** phone will cycle through its list of up to 5 emergency number (or up to 3 "Info" phone numbers), before it stops the dialing process and hangs up. When all of the programmed phone numbers have been dialed, the lap counter is incremented and the dialing process repeats. When the lap counter has been met, the dialing process stops and the **1600A Series** phone hangs up. **\*Note:** *This feature is disabled in the factory default setting.*

Touch Tone	Setting F
0	Disabled*
1-9	Lap count: 1-9 times

## H. Recording the Announcement

<b>Step 1</b>	Call into the <b>1600A Series</b> phone with a Touch Tone phone and access the programming mode as shown on page 6.
<b>Step 2</b>	Enter *4, wait for the tone and then begin recording. <b>Note:</b> <i>There are 16 seconds of record time is available.</i>
<b>Step 3</b>	Enter any Touch Tone to stop the recording. <b>Note:</b> <i>Playback is automatic.</i>
<b>Step 4</b>	Enter *5 to review the announcement again.
<b>Step 5</b>	If you choose to not use a voice announcement, enter *3 to clear the recording.

**Example:** "Elevator number 1215, located in the Financial Building, needs assistance. Press the asterisk (\*) key on your telephone to hear this announcement again."

## I. Assisted Programming

When attempting to program the 1600A Series emergency phone, if the phone number of the line it is connected to is not known, the phone can be set to automatically call Viking technical support for assistance. With DIP switch 3 set to OFF (programming mode), pushing the CALL button will cause the **1600A Series** phone to call Viking, whether it be connected directly to a CO line, or behind a "dial 9" PBX.

The **1600A Series** phone will first dial 9, and then listen for second dial tone; if detected it will continue to dial Viking's assisted programming phone number. If a second dial tone is not detected, it then knows it is not behind a PBX, so it will momentarily hang up and then directly dial Viking's assisted programming phone number. Since this is a long distance phone call, the line must be capable of placing long distance calls for the call to go through. When finished programming, it is very important to set DIP switch 3 back to ON (normal operating mode), and place a test emergency call to be sure all programming was done properly.

**Warning: Failure to set DIP switch 3 back to ON when finished programming will cause the 1600A Series phone to call Viking Technical Support, instead of your programmed emergency number. Yet, as a fail-safe measure, after 3 calls to Viking, the unit will ignore switch 3 and dial its programmed phone numbers.**

## J. DIP Switch Programming/Speaker and Microphone Adjustments

A speaker volume POT is provided to increase or decrease the speakerphone volume. **Note: The Microphone Sensitivity POT has been removed because the microphone sensitivity is now microprocessor controlled. This allows the mic gain to be automatically increased in a quiet environment, allowing the distant party to clearly hear even soft or distant sounds. The microprocessor will automatically reduce the mic sensitivity when the location becomes noisy. This Automatic Noise Canceling (ANC) feature will allow speakerphone two-way communications to continue to work properly, even when subjected to loud noise such as a diesel engine or traffic.**

Switch A	Switch B	Description
ON	ON	Normal audio detection
OFF	OFF	Increase audio detect sensitivity for low level lines. Useful in applications in which voice or busy signals have trouble breaking over the speaker.

Switch	Position	Description
1	ON	"HELP" button alternately connects/disconnects calls (factory default)
1	OFF	"HELP" button connects calls only
2	ON	Incoming calls answered (factory setting)
2	OFF	Incoming calls are not answered
3	ON	Normal operation mode (factory setting)
3	OFF	Learn mode - Any incoming calls are automatically entered into the programming mode (no security code required). Use this option if you have forgotten your security code. Any outbound call will dial Viking Technical Support (see section I). <b>Warning: When finished programming, set this switch back to the ON position, otherwise the 1600A Series phone will only call Viking Technical Support instead of your programmed emergency number.</b>

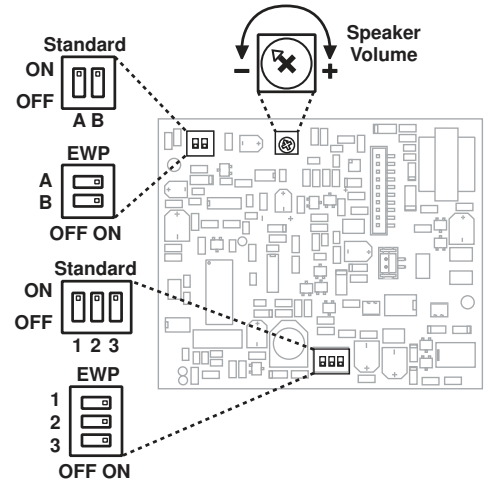

## K. Central Station Programming

The standard **1600A** emergency phone is capable of communicating using the "Ademco Contact I.D.", "Ademco High Speed", "DTMF 4+1 Express", or the "DTMF 4+2 Express" formats. All formats use the programming memory location **#20** to store the account code and alarm details.

### 1. Central Station Programming Features

#### a. Accessing the Programming Mode

Before programming, you must access the programming mode (see **Programming** section A).

#### b. Enabling/Disabling Central Station Mode

The **1600A** Series emergency phone can be placed in the "Central Station Mode" by entering a central station phone number in position **#05** while programming. To cancel the "Central Station Mode," clear position **#05** by entering **#05** only (see **Programming** section D).

To Program the 1600A Series Phone...	Step 1:	Step 2 - Enter Digits:
...to enable central station programming and dial 952-2567	Enter Programming (see page 6)	<b>9 5 2 2 5 6 7 # 0 5</b>
...to disable central station programming	Enter Programming (see page 6)	<b># 0 5</b>

#### c. Ring No Answer

When the **1600A** Series emergency phone is in the "Central Station Mode", it is best to have the ring no answer set to a minimum of three, because some receivers send a long tone after answering the line that sounds like a ring back. If the **1600A** is set to a ring no answer of two, the phone will disconnect (see **Programming** section F).

#### d. Speed Dial Numbers

The **1600A** Series phone can be programmed to dial a central station receiver only, or dial up to 5 voice numbers first, and if no answer, then dial the central station receiver. When calling the first numbers (memory positions **#00-#04** (see **Programming** section D), the phone stays in "two-way talk mode" allowing two-way conversation. When calling the Central Station number (memory position **#05**), the phone is in a "listen only mode" in order to interpret the hand shake signals of the receiver.

A second central station number position has been provided in location **#06** that is used when the central station receiver does not have a talk over mode. If a number is placed in position **#05** and position **#06** is cleared, the **E-1600A** will call the central station monitor receiver. One or two alarm messages can be sent to the receiver (see **Operation** section B, note 3). After the receiver sends a kiss-off, the **E-1600A** lights the "Call Connected" LED and goes into two-way talk mode. If numbers are in both positions **#05** and **#06**, the **E-1600A** will call the receiver first, and after the kiss-off, will hang-up and redial the number in position **#06** for two-way voice communication.

**Note: If only a central station is to be dialed, the central station phone number must be preprogrammed in memory location #05 and memory locations #00-#04 must be cleared.**

Location	Call Type
<b>#00</b>	Voice - Emergency
<b>#01</b>	Voice - Emergency
<b>#02</b>	Voice - Emergency
<b>#03</b>	Voice - Emergency
<b>#04</b>	Voice - Emergency
<b>#05</b>	Central Station Receiver
<b>#06</b>	Central Station Voice Line
<b>#07</b>	Voice - "Info" (E-1600-20A/52A only)
<b>#08</b>	Voice - "Info" (E-1600-20A/52A only)
<b>#09</b>	Voice - "Info" (E-1600-20A/52A only)

## 2. Central Station Formats

The following examples explain the receiver formats and how to properly program memory location #20. Each format starts with a four digit account code. This is the code that is assigned by your central station for billing purposes. You must access the programming mode before programming these features (see **Programming** section A). **Important:** If a number is shown, you must use that number. If an “X” is shown, use any appropriate number. **Note:** A second information alarm message can be sent to the receiver, for any receiver that requires two separate messages. The second alarm message is programmed in #21 location. For additional information about the second alarm message, see **Operation** section B.

Ademco Contact ID Format	XXXX	18	1	14000	XXX	#20
This DTMF format consists of a four digit account code, two digit message type, and a nine digit data field.	Account Code	Message Type	New Event	General Alarm	Number to identify phone	Memory Location
<b>Enter Contact ID Settings Here:</b>	— — — —	18	1	14000	— — —	#20

Sometimes the central station receiver requires a secondary “listen-in to follow” code to be sent. This can be accomplished by programming memory location #21 as shown right. * <b>Note:</b> Set the account code and the identifier the same as memory location #20.	XXXX *Account Code	18 Message Type	1 New Event	60600 Listen-In to Follow	XXX *Number to identify phone	#21 Memory Location
--	-----------------------	--------------------	----------------	------------------------------	----------------------------------	------------------------

Ademco High Speed Format	XXXX	55	1	55555	7	#20
This DTMF format consists of a four digit account code, eight zone codes and one alarm type digit. With this format you can identify up to eight different phones by using a zone per phone. A “5” in a zone position means no alarm. The following example shows an alarm from the third phone.	Account Code	Idle Zones	Alarmed Zone	Idle Zones	Normal Alarm	Memory Location
<b>Enter Ademco High Speed IP Settings Here:</b>	— — — —	55	1	55555	7	#20

4+1 Express Format	XXXX	17	X	#20
This DTMF format consists of a four digit account code, two digit message type, and a single digit event code.	Account Code	Message Type	Event Code	Memory Location
<b>Enter 4+1 Express ID Settings Here:</b>	— — — —	17	—	#20

4+2 Express Format	XXXX	27	XX	#20
This DTMF format consists of a four digit account code, two digit message type, and a two digit event code.	Account Code	Message Type	Event Code	Memory Location
<b>Enter 4+2 Express ID Settings Here:</b>	— — — —	27	— —	#20

# Operation

## A. Standard Operation

### 1. “HELP” Button

When the “HELP” button is pressed, the **1600A Series** phone goes off-hook and dials a pre-programmed telephone number. The Call Connected LED momentarily flashes during tone or pulse dialing. In the event the line is busy or there is a ring-no-answer, the unit can be programmed to call additional phone numbers.

The phone then cycles through up to 5 pre-programmed emergency numbers until the call is answered. When the call is answered, the digital voice announcer will automatically play to identify the location of the emergency call. The phones are factory programmed to play the announcement once, and then automatically light the “Call Connected” LED to show that handsfree communication to emergency personnel is established. The \* key will send the I.D. number (if programmed), and play the announcement again. The distant party will know the location of the emergency call by either the voice announcement or by decoding the Touch Tone I.D. number. Once the “Call Connected” LED is on, the # key can be used to force the phone to hang-up.

## 2. "INFO" Button (E-1600-20A and E-1600-52A Only)

When the "INFO" button is pressed (E-1600-20A and E-1600-52A only), the phone goes off-hook and dials the first "INFO" phone number programmed. If a busy signal is detected or the call goes unanswered, the phone will cycle through all three "INFO" phone numbers until the call is answered. When answered, handsfree communication is established. **Note:** The voice announcement is for **Emergency/Help** calls only and will not play on a call initiated from the "INFO" button.

## B. Central Station Operation

After the "HELP" button on the 1600A Series phone has been pressed the 1600A Series phone will begin to dial. If a voice number is programmed in memory locations #00-#04, these numbers will be dialed first. Upon detecting a busy signal or after a preprogrammed ring delay the 1600A Series phone will hang-up and dial the central station phone number stored in memory location #05. When the central station receiver answers, it will send a handshake tone to the 1600A phone. Upon detecting the handshake tone, the 1600A Series phone will begin uploading the information stored in memory location #20.

Once the 1600A Series emergency phone has sent the information stored in memory location #20, it waits for a "kiss-off" tone from the central station. When the "kiss-off" tone is received, the emergency phone turns on the call connected LED and goes into the "two-way talk mode" or hangs up and dials position #06 if programmed (see Note 3 below).

- Notes:**
1. The central station should have a "talk-over" feature that will allow a two-way conversation at this time. If your receiver does not support "talk-over", a voice phone number should be programmed into position #06.
  2. If the central station answers the call, sends the handshake tone, but does not send a "kiss-off" tone after the information is sent, the 1600A resends the information three additional times, waiting for a "kiss-off" after each attempt. If "kiss-off" has not been received after the fourth attempt, the 1600A hangs up and dials position #05 again.
  3. The 1600A has the capability to send a second informational message to the receiver after the first "kiss-off" is received, but only if a second informational message is stored in memory location #21. After the first "kiss-off" is received, the 1600A sends the information stored in memory location #21. It then waits for a second "kiss-off" from the central station receiver. When the second "kiss-off" is received, the emergency phone turns on the call connected LED and goes into the "two-way talk mode" or hangs up and dials position #06 if programmed.

## Warranty

### IF YOU HAVE A PROBLEM WITH A VIKING PRODUCT, CONTACT: VIKING TECHNICAL SUPPORT AT 715-386-8666

Our Product Support Department is available for assistance Monday - Friday 8am - 5pm central time. So we can give you better service, before you call please:

1. Know the model number, the serial number and what software version you have (see serial label).
2. Have your Product Manual in front of you.
3. It is best if you are on site.

#### RETURNING PRODUCT FOR REPAIR

The following procedure is for equipment that needs repair:

1. Customer must contact Viking's Technical Support Department at 715-386-8666 to obtain a Return Authorization (RA) number. The customer MUST have a complete description of the problem, with all pertinent information regarding the defect, such as options set, conditions, symptoms, methods to duplicate problem, frequency of failure, etc.
2. Packing: Return equipment in original box or in proper packing so that damage will not occur while in transit. Static sensitive equipment such as a circuit board should be in an anti-static bag, sandwiched between foam and individually boxed. All equipment should be wrapped to avoid packing material lodging in or sticking to the equipment. Include ALL parts of the equipment. C.O.D. or freight collect shipments cannot be accepted. Ship cartons prepaid to: **Viking Electronics, 1531 Industrial Street, Hudson, WI 54016**
3. Return shipping address: Be sure to include your return shipping address in the box. We cannot ship to a PO Box.
4. RA number on carton: In large printing, write the R.A. number on the outside of each carton being returned.

#### RETURNING PRODUCT FOR EXCHANGE

The following procedure is for equipment that has failed out-of-box (within 10 days of purchase):

1. Customer must contact Viking's Technical Support at 715-386-8666 to determine possible causes for the problem. The customer MUST be able to step through recommended tests for diagnosis.
2. If the Technical Support Product Specialist determines that the equipment is defective based on the customer's input and troubleshooting, a Return Authorization (R.A.) number will be issued. This number is valid for fourteen (14) calendar days from the date of issue.
3. After obtaining the R.A. number, return the approved equipment to your distributor, referencing the R.A. number. Your distributor will then replace the Viking product using the same R.A. number.
4. The distributor will NOT exchange this product without first obtaining the R.A. number from you. If you haven't followed the steps listed in 1, 2 and 3, be aware that you will have to pay a restocking charge.

### TWO YEAR LIMITED WARRANTY

Viking warrants its products to be free from defects in the workmanship or materials, under normal use and service, for a period of two years from the date of purchase from any authorized Viking distributor. If at any time during the warranty period, the product is deemed defective or malfunctions, return the product to Viking Electronics, Inc., 1531 Industrial Street, Hudson, WI, 54016. Customer must contact Viking's Technical Support Department at 715-386-8666 to obtain a Return Authorization (R.A.) number.

This warranty does not cover any damage to the product due to lightning, over voltage, under voltage, accident, misuse, abuse, negligence or any damage caused by use of the product by the purchaser or others. This warranty does not cover non-EWP products that have been exposed to wet or corrosive environments. This warranty does not cover stainless steel surfaces that have not been properly maintained.

**NO OTHER WARRANTIES.** VIKING MAKES NO WARRANTIES RELATING TO ITS PRODUCTS OTHER THAN AS DESCRIBED ABOVE AND DISCLAIMS ANY EXPRESS OR IMPLIED WARRANTIES OR MERCHANTABILITY OR FITNESS FOR ANY PARTICULAR PURPOSE.

**EXCLUSION OF CONSEQUENTIAL DAMAGES.** VIKING SHALL NOT, UNDER ANY CIRCUMSTANCES, BE LIABLE TO PURCHASER, OR ANY OTHER PARTY, FOR CONSEQUENTIAL, INCIDENTAL, SPECIAL OR EXEMPLARY DAMAGES ARISING OUT OF OR RELATED TO THE SALE OR USE OF THE PRODUCT SOLD HEREUNDER.

**EXCLUSIVE REMEDY AND LIMITATION OF LIABILITY.** WHETHER IN AN ACTION BASED ON CONTRACT, TORT (INCLUDING NEGLIGENCE OR STRICT LIABILITY) OR ANY OTHER LEGAL THEORY, ANY LIABILITY OF VIKING SHALL BE LIMITED TO REPAIR OR REPLACEMENT OF THE PRODUCT, OR AT VIKING'S OPTION, REFUND OF THE PURCHASE PRICE AS THE EXCLUSIVE REMEDY AND ANY LIABILITY OF VIKING SHALL BE SO LIMITED.

IT IS EXPRESSLY UNDERSTOOD AND AGREED THAT EACH AND EVERY PROVISION OF THIS AGREEMENT WHICH PROVIDES FOR DISCLAIMER OF WARRANTIES, EXCLUSION OF CONSEQUENTIAL DAMAGES, AND EXCLUSIVE REMEDY AND LIMITATION OF LIABILITY, ARE SEVERABLE FROM ANY OTHER PROVISION AND EACH PROVISION IS A SEPARABLE AND INDEPENDENT ELEMENT OF RISK ALLOCATION AND IS INTENDED TO BE ENFORCED AS SUCH.

#### FCC REQUIREMENTS

This equipment complies with Part 68 of the FCC rules and the requirements adopted by the ACTA. On the side of this equipment is a label that contains, among other information, a product identifier in the format US:AAEQ##TXXXX. If requested, this number must be provided to the telephone company.

The REN is used to determine the number of devices that may be connected to a telephone line. Excessive REN's on a telephone line may result in the devices not ringing in response to an incoming call. In most but not all areas, the sum of the REN's should not exceed five (5.0). To be certain of the number of devices that may be connected to a line, as determined by the total REN's, contact the local telephone company. For products approved after July 23, 2001, the REN for this product is part of the product identifier that has the format US:AAEQ##TXXXX. The digits represented by ## are the REN without a decimal point (e.g., 03 is a REN of 0.3). For earlier products, the REN is separately shown on the label.

The plug used to connect this equipment to the premises wiring and telephone network must comply with the applicable FCC Part 68 rules and requirements adopted by the ACTA. If your home has specially wired alarm equipment connected to the telephone line, ensure the installation of this 1600A Series phone does not disable your alarm equipment. If you have questions about what will disable alarm equipment, consult your telephone company or a qualified installer.

If the 1600A Series phone causes harm to the telephone network, the telephone company will notify you in advance that temporary discontinuance of service may be required. But if advance notice isn't practical, the telephone company will notify the customer as soon as possible. Also, you will be advised of your right to file a complaint with the FCC if you believe it is necessary.

The telephone company may make changes in its facilities, equipment, operations, or procedures that could affect the operation of the equipment. If this happens, the telephone company will provide advance notice in order for you to make the necessary modifications to maintain uninterrupted service.

If trouble is experienced with the 1600A Series phone, for repair or warranty information, please contact:

**Viking Electronics, Inc., 1531 Industrial Street, Hudson, WI 54016 (715) 386-8666**

If the equipment is causing harm to the telephone network, the telephone company may request that you disconnect the equipment until the problem is resolved. Connection to Party Line Service is subject to State Tariffs. Contact the state public utility commission, public service commission or corporation commission for information.

**WHEN PROGRAMMING EMERGENCY NUMBERS AND (OR) MAKING TEST CALLS TO EMERGENCY NUMBERS:** Remain on the line and briefly explain to the dispatcher the reason for the call. Perform such activities in the off-peak hours, such as early morning or late evenings.

It is recommended that the customer install an AC surge arrester in the AC outlet to which this device is connected. This is to avoid damaging the equipment caused by local lightning strikes and other electrical surges.

#### PART 15 LIMITATIONS

This equipment has been tested and found to comply with the limits for a Class A digital device, pursuant to Part 15 of the FCC Rules. These limits are designed to provide reasonable protection against harmful interference when the equipment is operated in a commercial environment. This equipment generates, uses, and can radiate radio frequency energy and, if not installed and used in accordance with the instruction manual, may cause harmful interference to radio communications. Operation of this equipment in a residential area is likely to cause harmful interference in which case the user will be required to correct the interference at his own expense.

## Product Support: 715-386-8666

Due to the dynamic nature of the product design, the information contained in this document is subject to change without notice. Viking Electronics, and its affiliates and/or subsidiaries assume no responsibility for errors and omissions contained in this information. Revisions of this document or new editions of it may be issued to incorporate such changes.